

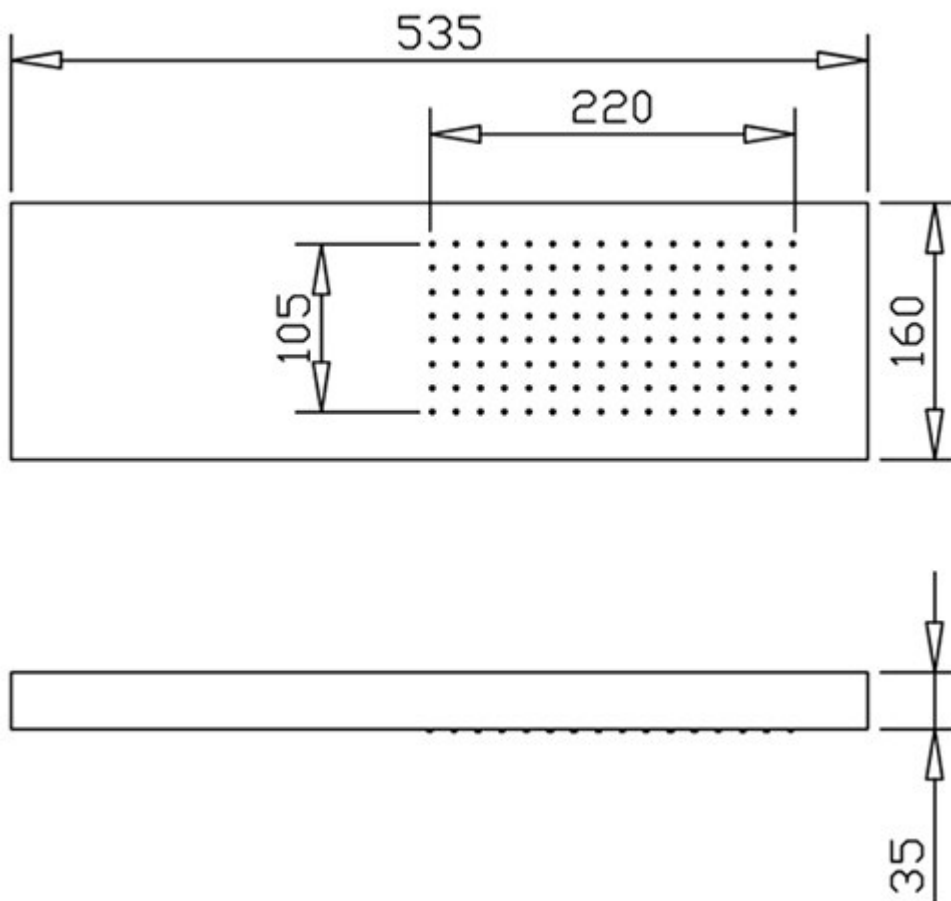

Soffioni a parete e a soffitto

Articolo NS502

Soffione rettangolare a parete in acciaio inox anticalcare, misure 535x160x36 mm con getto a pioggia, completo di kit di installazione.





GABOLI FRATELLI
RUBINETTERIA

ISTRUZIONI DI INSTALLAZIONE SOFFIONE NS502:

Pack		Contenuto confezione Package contents Contenu de l'emballage Packungsinhalt Contenido del paquete
		NS502 X1
		X1
		X1
		X1
		X1
10 mm		X2
		X1
		X1
		X4
IT Istruzioni di montaggio GB Mounting instructions FR Instructions de montage DE Montageanweisungen ES Instrucciones de montaje		X1



IT Diagramma di flusso
GB Flow rate
FR Le débit
DE Flussdiagramm
ES Diagrama de caudal



IT Indossare protezioni
GB Wear protection
FR Porter une protection
DE Schütze anziehen
ES Usar protección



IT Caratteristiche idrauliche
GB Plumbing specifications
FR Caractéristiques hydrauliques
DE Hydraulische Eigenschaften
ES Características hidráulicas



IT Pressione d'uso
GB Operating pressure
FR Pression d'utilisation
DE Betriebsdruck
ES Presión de uso



IT Temperatura dell'acqua
GB Water temperature
FR Température de l'eau
DE Wassertemperatur
ES Temperatura del agua



IT Litri d'acqua al minuto
GB Liters of water per minute
FR Litres d'eau par minute
DE Liter Wasser pro Minute
ES Litros de agua por minuto

NS502

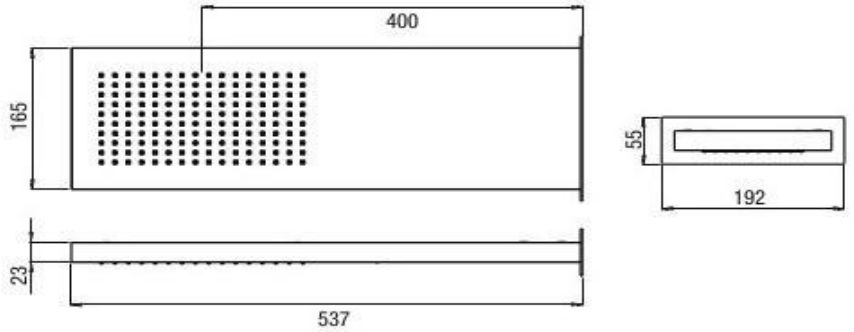
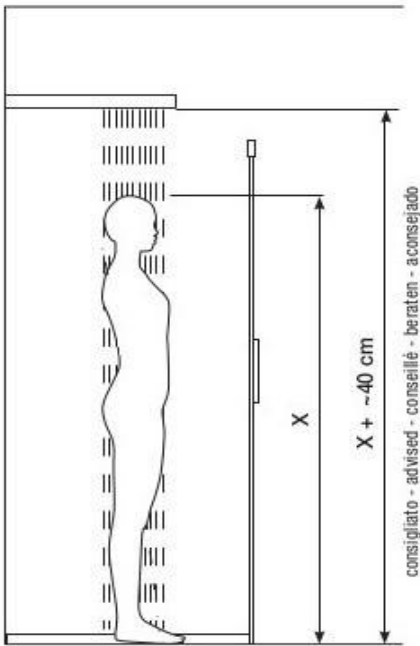

RAIN



- IT** | Portata l/min. pioggia
- GB** | l/min. rain flow
- FR** | Débit l/min. pluie
- DE** | l/min. Regenfluss
- ES** | Caudal l/min. lluvia



Tabella di Portata (Litri/min)

Bar	Pressione Dinamica (bar) / Portata (Litri/min)									
	0,5	1	1,5	2	2,5	3	3,5	4	4,5	5
	7,5	9,8	11,5	12,2	12,8	13,3	14,8	13,9	14,1	14



MIN 1 Bar
MAX 5 Bar
BEST 3 Bar

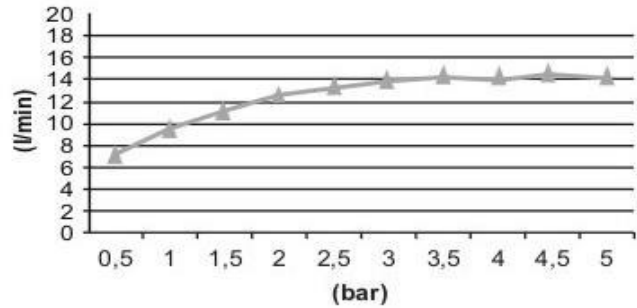

MAX 70° C
BEST 38°/40° C

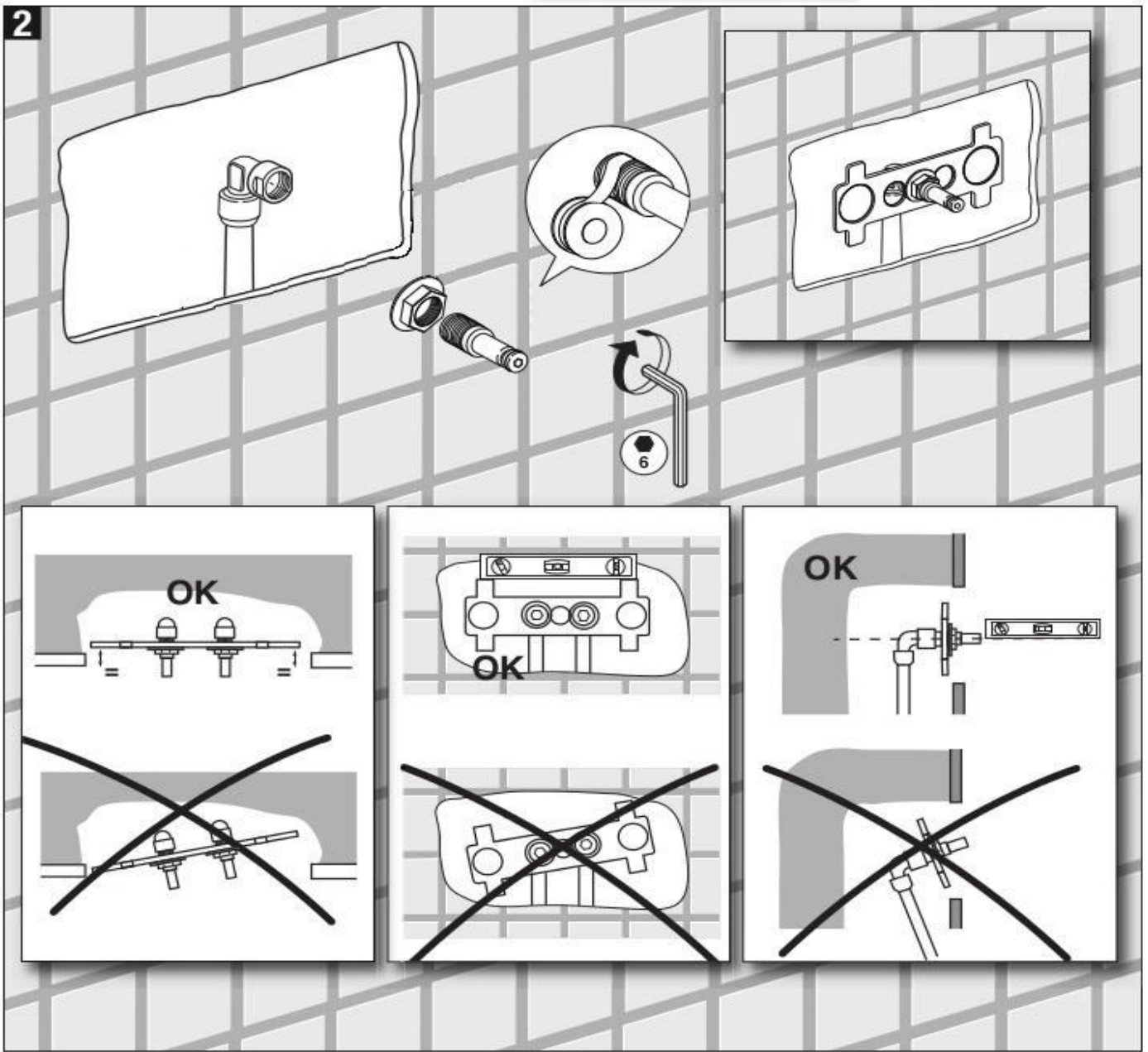
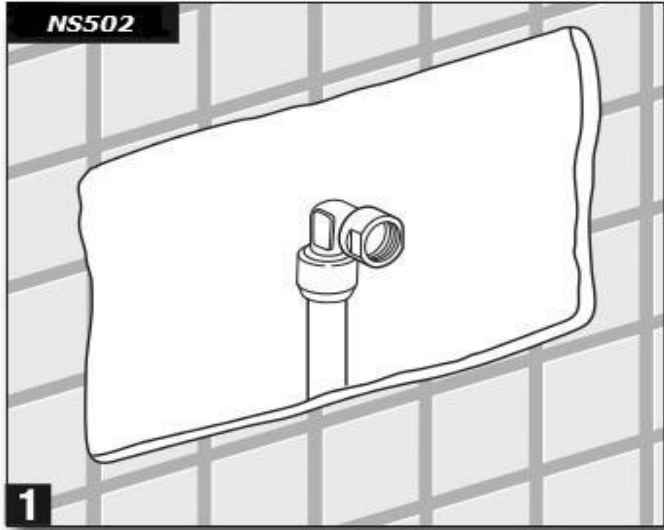

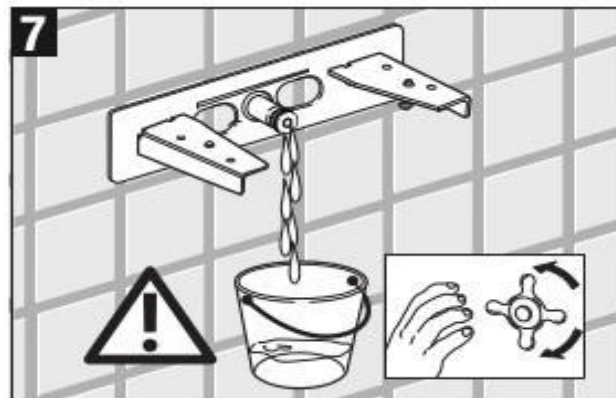
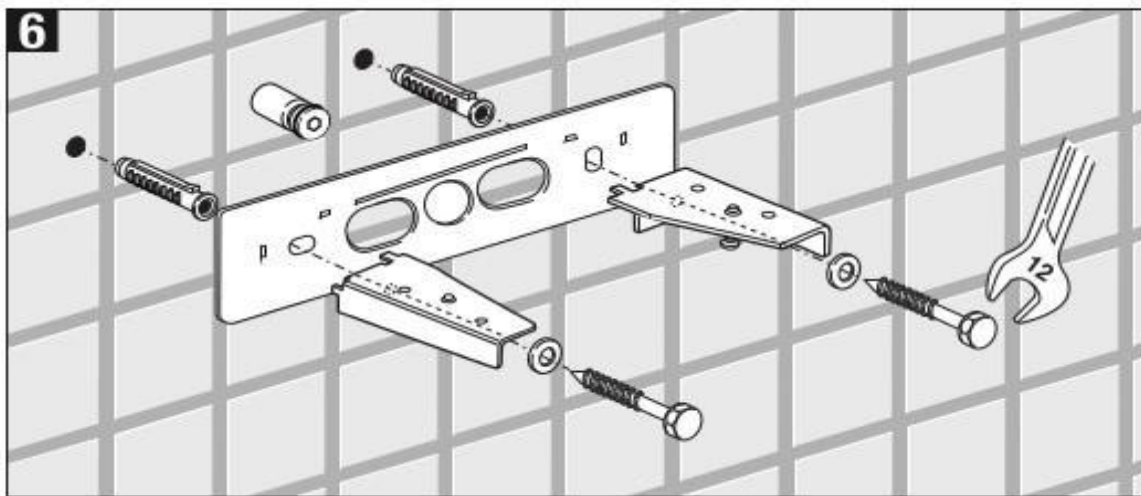
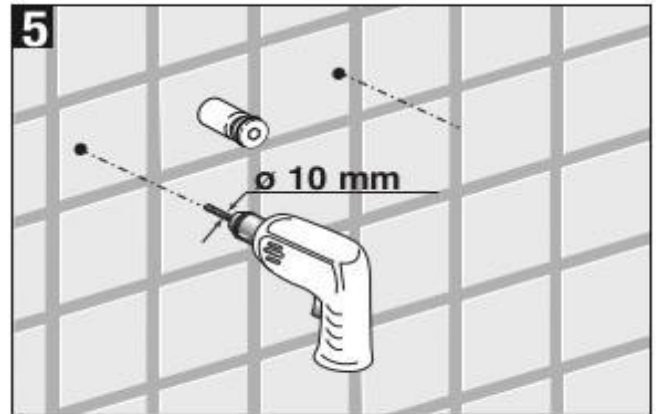
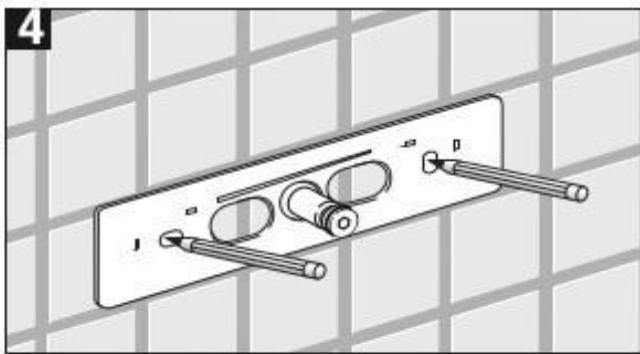
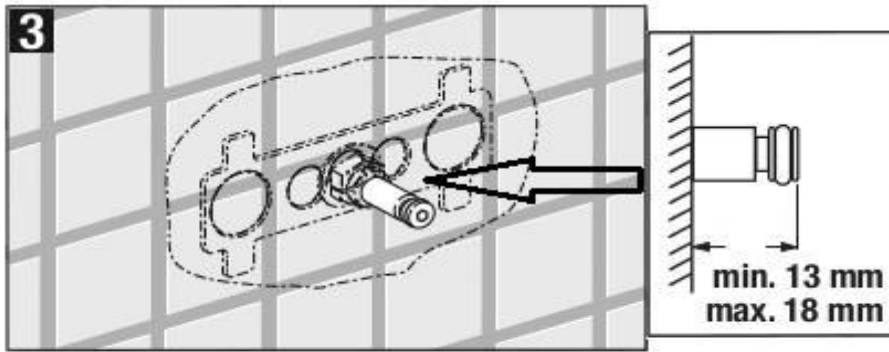

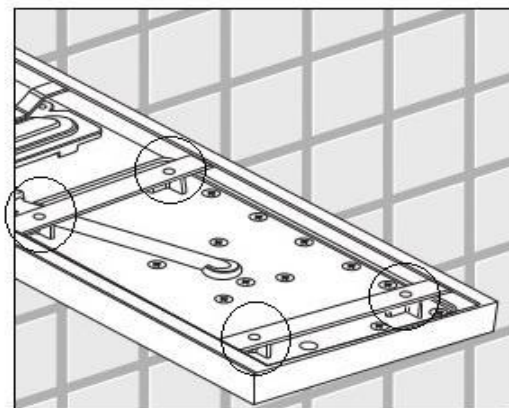
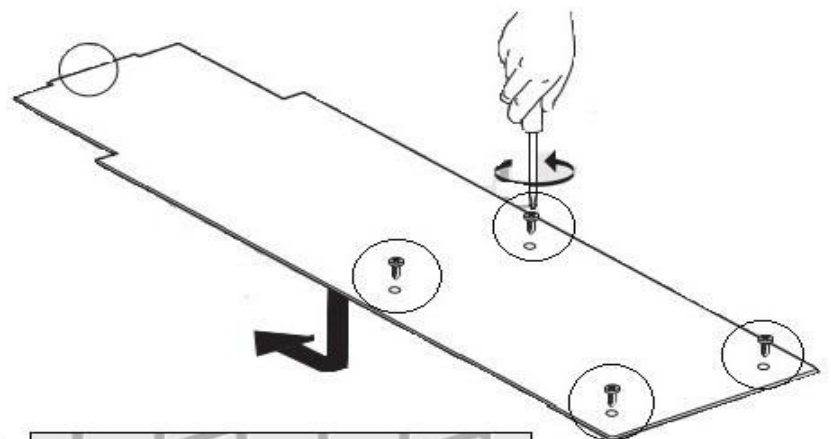
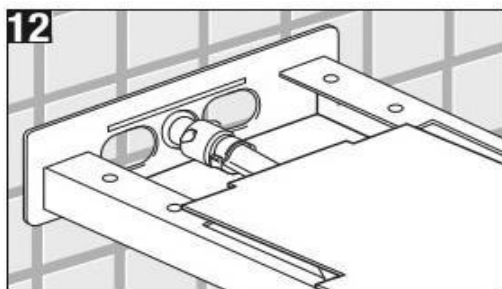
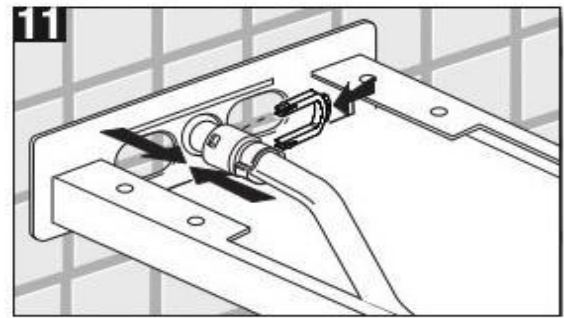
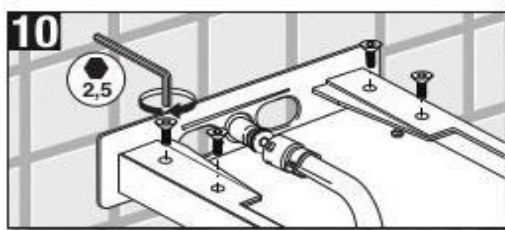
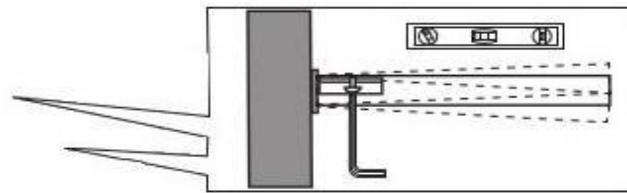
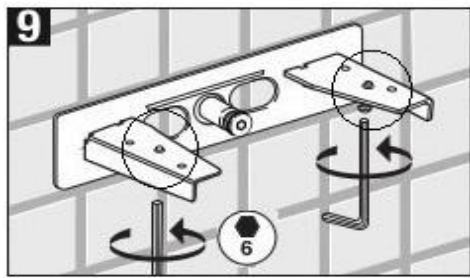
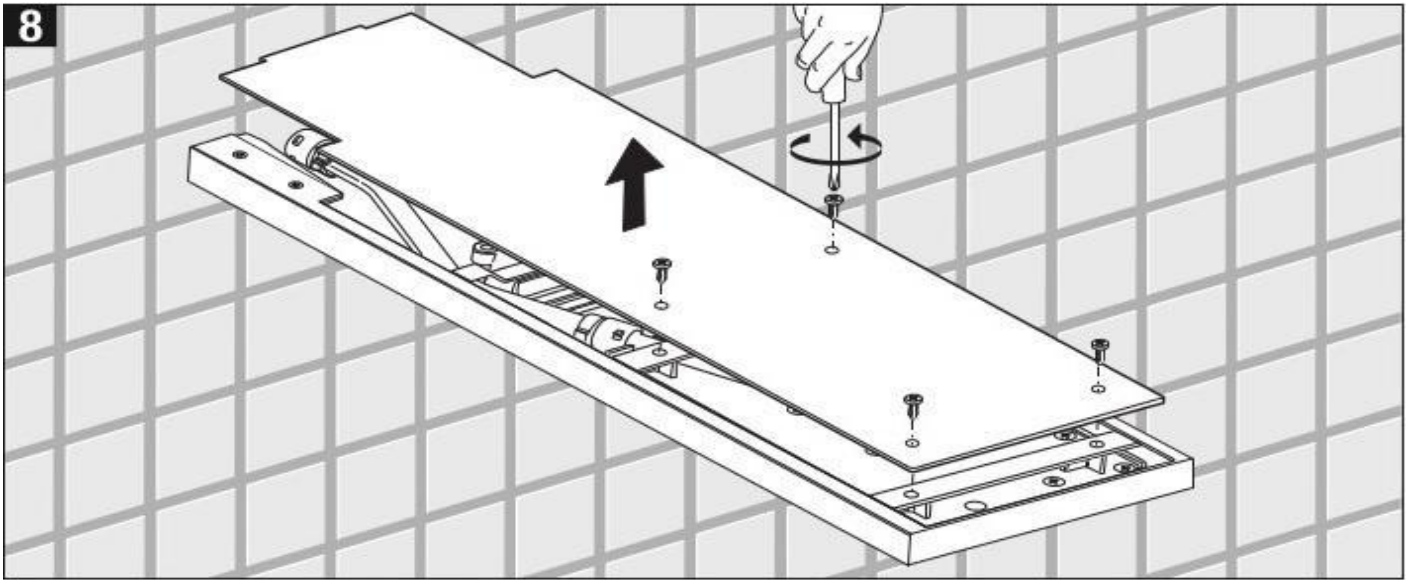

Cleaning



Suggerimenti per la pulizia
Cleaning Tips
Conseils de nettoyage
Reinigung Tipps
Consejos de limpieza

NS502

1

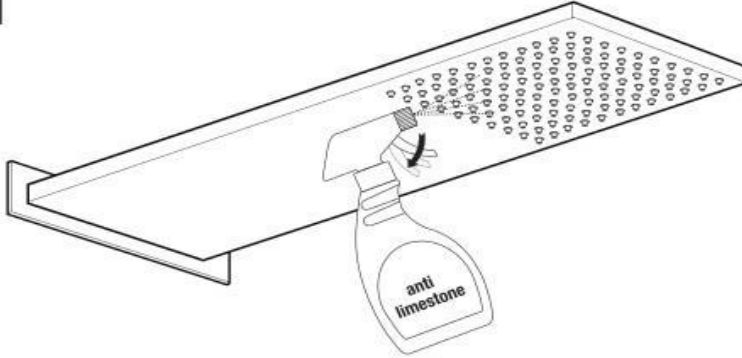

2

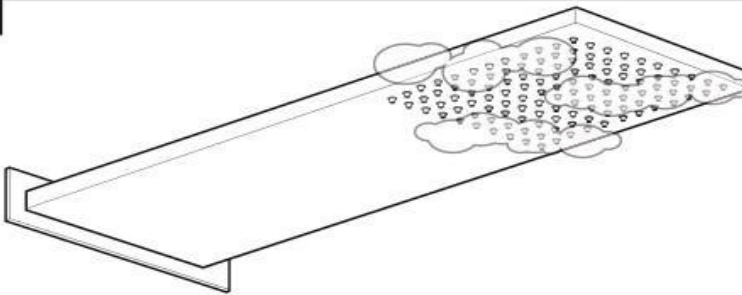

10 min

3

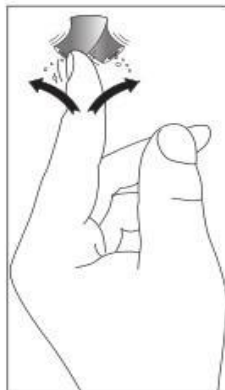
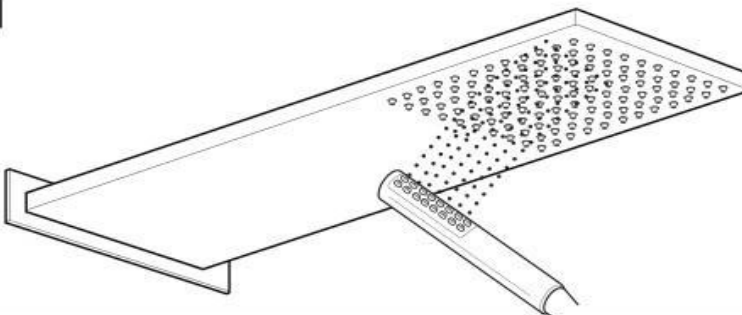

Cura del prodotto | Maintenance of the product | Entretien du produit | Produktpflege | Cuidado del producto

Per evitare danni al vostro bagno o all'apparecchiatura acquistata vi invitiamo ad osservare le seguenti raccomandazioni di UTILIZZO:

- Spurgare l'impianto prima di collegare l'apparecchio.
- Pulire periodicamente la testata di erogazione acqua da eventuali depositi di calcare che potrebbero compromettere il corretto funzionamento.

Consiglio:

L'installazione di un impianto di filtraggio e addolcimento delle acque migliora e prolunga la vita dei nostri apparecchi e dell'impianto stesso.

PULIZIA PARTI METALLICHE:

Per la semplice pulizia delle parti metalliche del prodotto è sufficiente usare un panno morbido e inumidito con acqua e sapone o un prodotto anticalcare.

Per evitare la formazione di macchie, dovute alla presenza di calcio nell'acqua, si consiglia di asciugare con un panno dopo ogni uso.

Consiglio: si prega di usare solo detersivi naturali a base di sapone evitando quelli contenenti alcool, acido cloridrico o acido fosforico, candeggina, cloro, ecc., e quelli contenenti polveri abrasive.

Afin d'éviter des dégâts dans la salle de bain ou à l'appareil acheté, nous vous invitons à suivre le mode d'emploi suivant:

- Purger l'installation hydraulique avant de connecter l'appareil.
- Nettoyer périodiquement la tête de la lame des éventuels dépôts de calcaire qui pourraient compromettre leur correct fonctionnement.

Conseil:

L'installation d'une station de filtrage et d'adoucisseur d'eau améliore et allonge la durée de vie de nos appareils et même de l'installation.

NETTOYAGE COMPOSANTS MÉTALLIQUES :

Il faut nettoyer les parties métalliques avec un chiffon souple et trempé avec du savon et de l'eau ou bien avec un produit anticalcars. Afin d'éviter la formation des taches, déterminées par la présence de calcium dans l'eau, il faut essuyer et polir avec un chiffon souple après chaque usage.

Conseil : Prier de n'employer que des détergents simples, à base d'ingrédients naturels (savons) en évitant tous les produits qui contiennent de l'alcool, de l'acide chlorhydrique ou de l'acide phosphorique, de l'eau de Javel, chlore, etc., et ceux contenant de la poudre abrasive.

Para evitar daños en su cuarto de baño o de los equipos adquiridos, tenga en cuenta las siguientes recomendaciones para su uso:

- Haga correr el agua de la instalación antes de conectar el aparato.
- Limpie periódicamente la narana de la cascada para liberarla de los depósitos de caliza pueden evitar el correcto funcionamiento.

Consejo: la instalación de una planta de filtros y descalcificador mejora y prolonga la vida de nuestros aparatos y de la planta también.

To avoid damages to your bathroom or to the purchased equipment, please observe the following recommendations for use:

- Clean the plumbing before connecting the device.
- Periodically clean the water blade to avoid any limestone deposits that could compromise the good functioning.

Advice:

The installation of a filter and water-softener system improves and extends the life of the devices and of the plant itself.

CLEANING OF METAL PARTS:

For an easy cleaning of the metal parts of the product, simply use a soft cloth moistened in water and soap or an anti-limestone detergent.

To avoid spots caused by calcium in water, we advise drying with a cloth after each use.

Advice: please use only natural soap-based detergents avoiding those with alcohol, hydrochloric acid or phosphoric acid, bleach, chlorine etc. and those containing abrasive powders.

Um Schäden an Ihrem Badezimmer oder gekauften Geräte zu vermeiden, beachten Sie bitte folgende Empfehlungen für die Verwendung:

- Putzen Sie die Anlage vor dem Anschluss des Gerätes.
- Regelmäßige Reinigung der Fallkante von eventuellen Kalkablagerungen, die den Betrieb stören können.

Tip:

Die Installation von einer Filteranlage und einem Wasserenthärter verbessert und verlängert die Lebensdauer unserer Geräte und der Pflanze selbst.

REINIGUNG VON METALLTEILEN:

Zur einfachen Reinigung von Metallteilen ist ausreichend, um einen weichen Tuch mit Wasser und Seife oder einen Produkt gegen Kalk zu benutzen. Um die Färbung aufgrund der Anwesenheit von Kalk im Wasser zu vermeiden, sollten Sie mit einem Tuch nach jedem Gebrauch reinigen.

Tip: Verwenden Sie bitte nur natürliche Seife-basierte Waschmittel und vermeiden solche mit Alkohol, Salzsäure oder Phosphorsäure, Bleichmittel, Chlor usw. und diese mit Scheuerpulver.

LIMPIEZA DE LAS PIEZAS METÁLICAS:

Para la limpieza de piezas metálicas es suficiente utilizar un paño suave humedecido con agua y jabón o un producto anticál. Para evitar manchas, debido a la presencia de cal en el agua, se recomienda limpiar con un paño después de cada uso.

Consejo: Utilice únicamente detergentes naturales a base de jabón detergente y evite los que contienen alcohol, ácido clorhídrico o ácido fosfórico, lejía, cloro, etc., así como productos abrasivos.